

The MOST Microsatellite Mission: Canada's First Space Telescope

Dr. Kieran A. Carroll
 Manager, Space Projects
 Dynacon Enterprises Limited
 3565 Nashua Drive
 Mississauga, Ontario, Canada L4V 1R1
 905-672-8828 x232, kac@dynacon.ca

Dr. Robert E. Zee
 Manager, Space Flight Laboratory
 University of Toronto Institute for Aerospace Studies
 4925 Dufferin Street
 Toronto, Ontario, Canada M3H 5T6
 416-667-7864, rez@sdr.utias.utoronto.ca

Dr. Jaymie Matthews
 Asst. Professor, Department of Physics and Astronomy
 University of British Columbia
 129 - 2219 Main Mall
 Vancouver, British Columbia, Canada V6T 1Z4
 604-822-2696, matthews@astro.ubc.ca

Abstract. The MOST (Microvariability and Oscillations of STars) astronomy mission has been chosen by the Canadian Space Agency's Small Payloads Program to be Canada's first space science microsatellite, and is currently planned for launch in late 2001. The MOST science team will use the MOST satellite to conduct long-duration stellar photometry observations in space. A major science goal is to set a lower limit on the age of several nearby "metal-poor sub-dwarf" stars, which may in turn allow a lower limit to be set on the age of the Universe. To make these measurements, MOST will incorporate a small (15 cm aperture), high-photometric-precision optical telescope to be developed by UBC.

The MOST bus and ground stations are being developed by Dynacon and the University of Toronto, in collaboration with AMSAT Canada. Several of the bus subsystems are based on similar designs that have been flown on past AMSAT microsatellites. However, the MOST attitude control system is unusual for a microsatellite, requiring highly-accurate (< 30 arc-seconds) three-axis inertially-fixed stabilization, far better than can be achieved using the gravity-gradient boom stabilization approach typical of many past microsatellites. Dynacon will provide the MOST ACS, based on its Miniature Reaction Wheel (MRW) and High Performance Attitude Control (HPAC) products. MOST's HPAC capability will enable it to be one of the first *operational* space science microsatellites.

Introduction

A paper on the MOST mission¹ was provided in the 11th AIAA/USU Small Satellites Conference (poster session). Since then:

- A Phase A study was carried out, during which the requirements and the design for the mission were defined in greater detail, and some elements of the design were changed.
- A proposal was made to the Canadian Space Agency for a team led by Dynacon to develop this mission.
- That proposal was accepted by the CSA, and mission development has been initiated.

This paper summarizes the current development status of the MOST mission.

MOST and the CSA Small Payloads Program

In 1996, the Space Science Branch of the Canadian Space Agency initiated the Small Payloads Program (SPP) with an Announcement of Opportunity². The CSA has in the past supported missions employing balloon- and sounding-rocket-based science payloads, and the SPP extends this to include microsatellite-based missions. Based on its approved funding level, the SPP plans to launch one Canadian space science microsatellite mission every 3 years; these will be the first dedicated Canadian space science satellites since the Alouette and ISIS ionospheric topside sounding missions of the 1960s. The SPP will support missions within the three priority areas of the Canadian space science program:

- Space Astronomy
- Solar-Terrestrial Physics

- Atmospheric Studies

Early in 1998, the MOST mission was selected via a competitive process by the CSA to be the first microsatellite mission under the SPP. As part of that process, a Phase A study of MOST was carried out during 1997, during which requirements were defined in detail, and an initial preliminary design for the mission, the overall system, and each of the system's main components were developed. It is that design which is presented here.

Under the SPP, the CSA is procuring MOST as a complete *mission*. Dynacon and its team members will develop the mission's requirements, design and build the MOST satellite and its ground stations, support the launch of the satellite, and operate the satellite once it is in orbit. The CSA will provide the launch for the MOST satellite.

Note one of the most significant constraints of the SPP: the requirement that all missions be conducted at a very low cost, with a life-cycle cost cap of CDN\$4M (at current exchange rates, under US\$3M) for all activities to the end of the first year of operations. This will make MOST, and other SPP missions, among the lowest-cost space science missions ever attempted.

Mission Overview

Science Objectives

MOST is primarily a space astronomy mission. It employs a microsatellite platform to support a very small astronomical telescope. This will be used to collect light from nearby, bright target stars for measurement by a photometer, which will measure oscillations in brightness of the target stars. The frequencies of these oscillations can be used to infer fundamental properties of the stars, including their ages. This has already been done for the Sun, whose vibrations have been known since 1960. Extending this technique to other Sun-like stars will allow use to test theories of stellar structure and evolution, and offers an independent way to place a hard lower limit on the age of the Universe. This hasn't been possible before because the oscillation amplitudes observed in the Sun (a few parts per million in flux) are too small to be detected in other stars with ground-based telescopes.

Since the target stars are bright and provide high photon fluxes across wide bandpasses, a large telescope aperture isn't needed to ensure good signal-to-noise. The handicap has been noise due to atmospheric scintillation (what makes stars "twinkle"), so a small telescope in orbit can overcome this. Also, unlike instruments whose primary purpose is imaging, a photometer does not require a highly-focused image. The total light from a star can be integrated across the image profile on the detector, or

reimaged by optics into a sharp image of the telescope pupil, whose total brightness is then measured. Finally, very weak oscillation signals can be extracted from long time series of data by Fourier analysis or similar techniques.

Therefore, it is possible to perform cutting-edge astrophysics with a small telescope on an orbiting platform with only moderate pointing accuracy. MOST has found a way to do this using a very small, inexpensive satellite.

Public Participation

The MOST team anticipates considerable public interest in this mission. The mission has been defined to include two explicit mechanisms to allow members of the public to become directly involved.

The first is an Amateur Observer's Contest. To be administered by the Royal Astronomical Society of Canada, this will provide an opportunity for members of that organization and students to submit proposals for observing specific stellar targets. The MOST science team, the RASC and the CSA will select winning proposals. A portion of the MOST observing schedule will be set aside to observe the selected targets, and the data collected will be provided to the proposers for analysis.

The second involves AMSAT Canada, which will be contributing to the MOST mission in several ways. One contribution will be in the form of an amateur radio payload, allowing AMSAT members to use MOST as a communications relay. (The target payload is currently defined as an L-band uplink, S-band downlink transceiver, to support digital store-and-forward packet communications using existing AMSAT protocols.)

The MOST Team

A team has been assembled that has the technical background necessary to develop the elements of the MOST mission, and to conduct the scientific research at the heart of the mission. The composition of the team reflects additional, programmatic objectives of the SPP, such as to develop a Canadian industrial ability to produce low-cost space science missions based on microsatellite buses, and to involve universities in the development process.

Science Team

The Mission Scientist for MOST is Professor Jaymie Matthews, of the Department of Physics and Astronomy

at the University of British Columbia. Co-investigators include Slavek Rucinski (Canada-France-Hawaii Telescope), Professor Anthony Moffat (Université de Montréal), Dimitar Sasselov (Harvard-Smithsonian Center for Astrophysics), and David Guenther (Saint Mary's University, Halifax). This science team is developing the mission's detailed science requirements, as well as new theoretical stellar models to exploit photometric data whose precision is two orders of magnitude better than what has been possible from the ground.

Instrument Team

Dr. Matthews is also the Principal Investigator for the

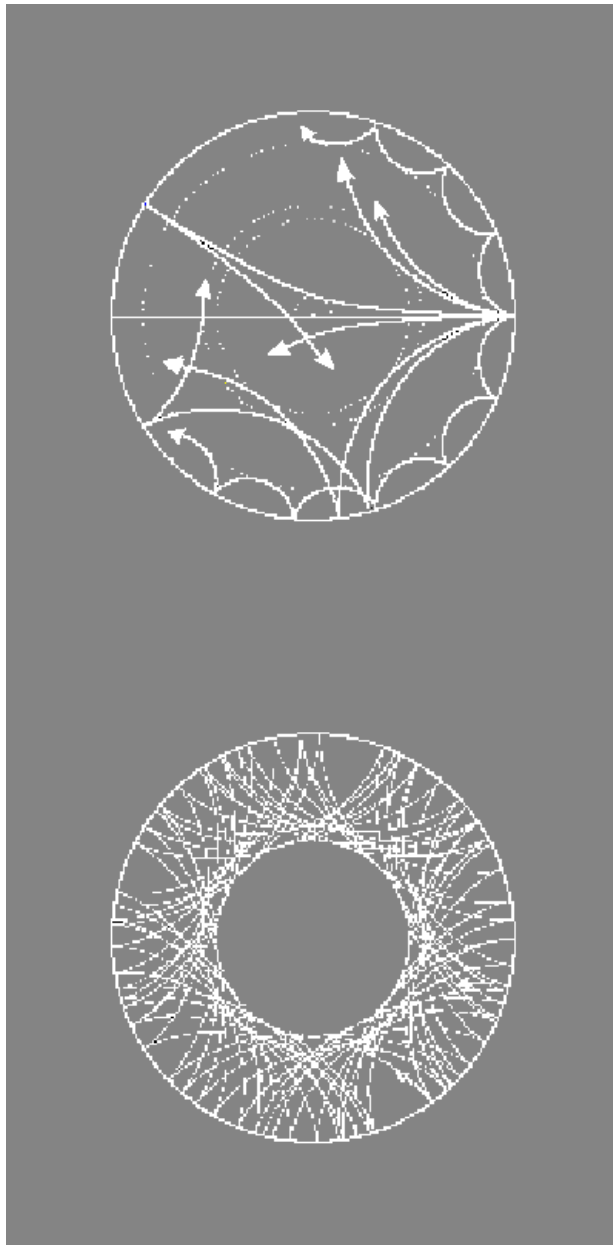

Figure 1: Sound Waves Propagating Within Acoustic Cavities In The Sun.

MOST mission, responsible for the design and construction of the instrument. A team of optical, mechanical and electronics engineers has been assembled at UBC, who already have a strong track record in CCD instrumentation for many of the world's largest and most advanced ground-based telescopes. The UBC team will also benefit from the assistance of the Ontario Centre for Research in Earth and Space Technology (CRESTech), which has expertise in structural design and instrument testing.

Industrial Team

Dynacon is prime contractor for MOST, and is responsible for overall project management as well as mission planning and system-level design. Dynacon will also develop the Attitude Control and Thermal Control subsystems for the MOST satellite bus. Dynacon's Project Manager for MOST is Kieran Carroll.

The remaining bus subsystems (structure, power, on-board computers and telemetry & telecommand), along with the ground stations, will be developed by the University of Toronto Institute for Aerospace Studies (UTIAS). The UTIAS team is led by Rob Zee. UTIAS will carry out development of these subsystems in collaboration with AMSAT Canada, with support from AeroAstro. In affiliation with AMSAT/NA, the designs used in AMSAT's Microsat series of satellites will be adapted for use by MOST.

Science Rationale and Objectives

Dr. Matthews has written a review of the principles of stellar seismology from space, available on the World Wide Web³. The basic points and their relevance to the MOST mission are summarised below.

The Challenge

Analysis of subtle solar oscillations with periods near five minutes (caused by sound waves refracted through the solar interior by the varying sound speed of the gas, as illustrated in Figure 1) has opened a new window on the structure of our nearest star—the Sun. Using instruments such as spectrographs (which measure solar surface velocities along the Sun/Earth vector) and photometers (which measure variations of solar brightness), this young technique of *helioseismology* has confirmed the essential accuracy of the Standard Solar Model (by which we calibrate all other stellar models), and even shed light on the need for new high-energy neutrino physics. Due to the Sun's proximity to Earth, imaging versions of these instruments can resolve oscillation patterns across the Sun's surface.

Figure 2: A Simulated Solar Oscillation Mode (Degree $l=20$, Azimuthal Order $m=16$, Radial Overtone $n=14$).

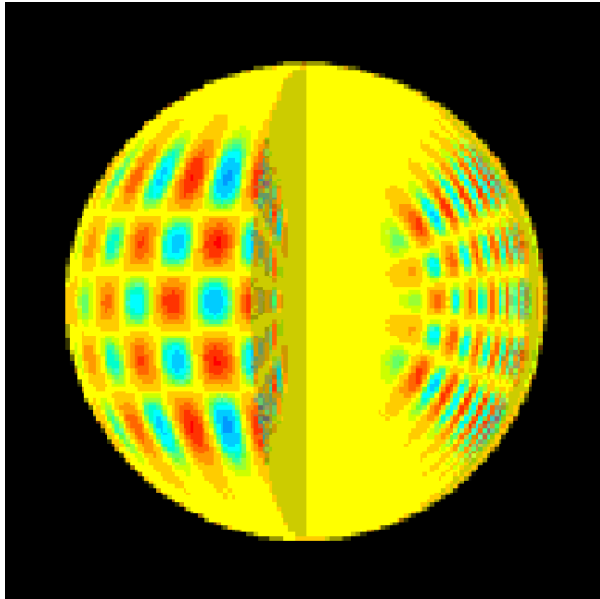

Astronomers would like to extend this technique to other Sun-like stars but have failed to make any clear detections to date. The challenge is illustrated by the case of the Sun. If the Sun’s light output is integrated across its entire surface (thus emulating the way that we see a distant unresolved star), the oscillation amplitudes are only a few cm/s in radial velocity and a few micromagnitudes (on the order of 10^{-6}) in flux. In order to achieve such velocity precision using spectrographic techniques would, even for the brightest stars, require the largest telescopes and much more stable spectrographs

than are currently available. In the case of photometry, photometric precision from Earth-based instruments is fundamentally limited by scintillation noise caused by our turbulent atmosphere. This can only be reduced from the ground by employing several telescopes of very large aperture over many months of time. A dedicated network of six ground-based 10-metre telescopes would be capable of seeing the five-minute oscillations in the brightest solar-type stars, but would have an estimated capital cost of US\$745M and an annual operating cost of about US\$90M.

The same goals are attainable with a single telescope of modest aperture (~ 15 cm) in orbit, above the scintillating atmosphere and monitoring stars in its Continuous Viewing Zone (CVZ—defined under “Mission Analysis”, below) for weeks to months, at a fraction of the cost of a terrestrial network.

The Requirements

The sound waves propagating within the Sun set up acoustic oscillation modes at the surface corresponding to different eigenfrequencies and spherical harmonic patterns, as shown in Figure 2. In other stars, all but the simplest mode patterns would average out over the visible disk, but the remaining modes would appear as a “comb” of nearly equally spaced frequencies in a Fourier power spectrum, as shown in Figure 3. The spacing depends on the sound travel time across the star—giving us its radius—while small deviations from that spacing are sensitive to the composition of the stellar core. Since a main sequence star like the Sun is gradually converting its supply of hydrogen into helium to produce energy, the core composition is a “clock” which keeps track of the star’s age.

In the solar eigenmode spectrum, adjacent frequencies are spaced by about $70 \mu\text{Hz}$; the fine structure can be as small as a few μHz . Frequency splitting due to the star’s rotation can easily be as small as $0.5 \mu\text{Hz}$. Therefore, to obtain the best asteroseismic data, the necessary frequency resolution demands an observing time baseline of about $1/0.2 \mu\text{Hz}$, or about 2 months.

Gaps in the time series will introduce alias peaks and sidelobes in the Fourier spectrum, increasing the “noise floor” out of which the comb-like signal pattern emerges. Two main factors drive the magnitude of this “noise”:

- The more photometrically precise the basic photometry data is, the lower will be the amplitude of the Fourier spectrum noise floor. Control of stray light in the instrument, and careful calibration of the instrument are then means for achieving this.
- The more nearly continuous the time coverage is, the lower the Fourier spectrum noise floor can be

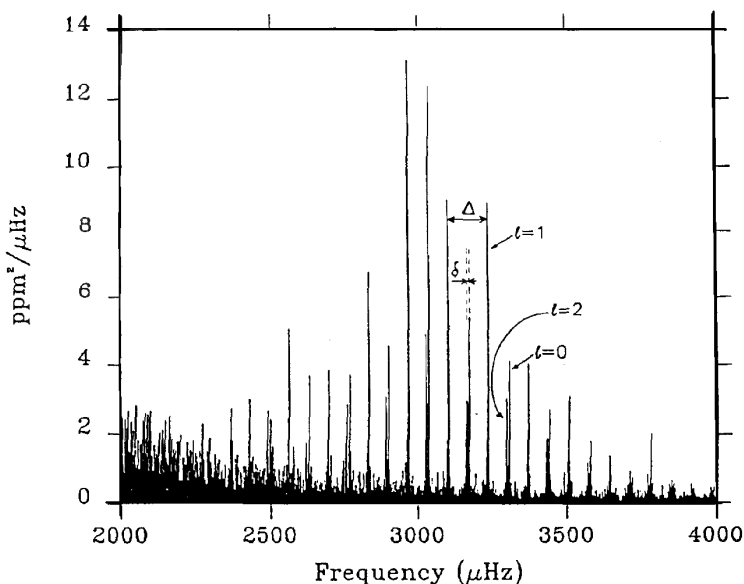

Figure 3: Fourier Power Spectrum of Solar Oscillations Observed Photometrically in Integrated Light with the IPHIR Photometer from Russian “Phobos” Mars Probe

pushed; good observations must cover at least 90% of the duration of the data record of each observing run, in order to produce a final photometric precision in the Fourier spectrum at the level of a few parts per million.

The Science Plan

MOST can satisfy all the data requirements at a relatively low cost. In a one-year mission, it could monitor at least six target stars and return the following results:

- ▶ First confirmed detection of Sun-like oscillations in another star (still not achieved from Earth), and resolution of acoustic eigenmode frequency spectra for these, allowing their ages to be estimated.
- ▶ First detection of p-mode oscillations in a “metal-poor” (i.e., very old) sub-dwarf star, and resolution of eigenmode frequency spectrum to determine star’s age. If the selected star is old enough, this could add new data to the current debate on the age of the Universe.
- ▶ Serendipitous detection of any Earth-sized planets whose orbits around the MOST target stars might cause eclipses and hence flux decreases on the order of 10 micromag.
- ▶ Accurate tracking of starspots carried around the stars’ surfaces by rotation.
- ▶ Very precise eigenfrequency spectra of one or two magnetic pulsating stars (roAp stars) whose fine-splitting also contains information about internal magnetic field strength and geometry - insights which are impossible to obtain in any other way.

Mission Concept

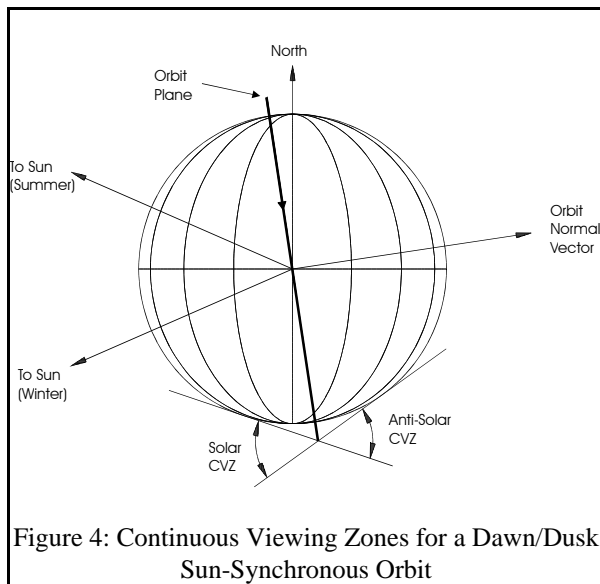

Driving Requirements

The MOST mission entails placing a low-cost satellite equipped with a high photometric precision telescope into Earth orbit, and using it to conduct observations on a series of stellar targets. There are two mission requirements that strongly constrain the choice of orbit and launch vehicle for MOST:

Long-Duration Uninterrupted Stellar Observations

Low cost implies a small satellite, and given the resulting small telescope aperture, long (up to 7 weeks) duration observations are required in order to achieve an adequate signal/noise ratio following analysis of a star’s photometry data. A nearly uninterrupted record of observations will improve the results of the analyses. The science team requires that no more than 10% of observations in a given period be missed.

Every Earth orbit has a Continuous Viewing Zone (CVZ) centered about each of the two orbit normal vectors; these are cones with half-angle equal to the declination of the Earth’s horizon below the satellite’s local “horizontal” plane, as illustrated in Figure 4. Stars located within the CVZ are visible from the satellite for the full duration of an orbit.

The science requirement implies that the CVZ “dwell” on each of the selected target stars for durations exceeding one month. This requirement is achievable only for near-polar and near-equatorial orbits.

Low Cost

The budget constraint for the project rules out all but the least expensive of launch opportunities. These include secondary payloads on launchers such as Delta and Ariane, and Get-Away Specials on a Space Shuttle. In each of these cases, the available mass and volume allocations are small, and the choice of orbit is dictated by the primary payload.

This requirement strongly favours orbits between about 600 and 900 km altitude. Above 900 km, high Van Allen belt radiation levels favour the use of expensive, rad-hardened electronic components over less-expensive, commercial-grade components. Below 600 km, the half-angle of the CVZ cone becomes so small that few stars are available for observations at any one time.

Baseline Orbit Selection

The orbit which has been chosen as the baseline for the MOST mission meets these requirements; it has the

following characteristics:

Sun-Synchronous

The orbital plane, and hence the CVZs for this type of orbit precess about the celestial poles at a rate of about 1°/day (i.e., one scan around the celestial sphere per solar year), providing access to a large number of stellar targets, but with a slow enough scan rate to allow long-duration observations. The orientation of the orbit plane with respect to the Sun does not change for this type of orbit, simplifying the effects of solar aspect angle on the satellite's power, thermal and payload design. Also, many Earth-observation satellites are launched into this type of orbit as primary payloads, creating many possible secondary payload opportunities.

Baseline Altitude

An 785 km altitude circular orbit has been baselined, equal to the altitude of Canada's Radarsat I satellite (the corresponding inclination is 98.6°). This is high enough to have a large CVZ (26° half-angle), resulting in target star dwell times within the CVZ of up to 7 weeks; it is also high enough that atmospheric drag will not significantly degrade the orbit within the first year of operations. This orbit is low enough to avoid severe radiation effects from the Van Allen belts.

Ascending Node

A dawn/dusk sun-synchronous orbit, with an ascending node of either 6 P.M. (like Radarsat) or 6 A.M., has been selected as the baseline for MOST. This offers particular advantages to the satellite design:

- The Sun always lies within about 35° of the center of one of the CVZs, while the other CVZ always points in the anti-Sunwards direction; the MOST telescope will target stars in the latter CVZ, allowing the body of the satellite to shield the telescope's aperture from the Sun. This eliminates the need for the type of large external baffle that would be needed in most other types of orbit.
- At the baseline altitude, this type of orbit does not experience eclipses for most of the year, and the maximum-duration eclipse is less than 15 minutes long (out of a 100-minute orbital period). This offers the potential to design the satellite's power subsystem with relatively small batteries, and for a relatively large fraction of solar-array power production to be available for direct use rather than for battery charging.
- For the >9 eclipseless months of the year the satellite's thermal environment will be almost static, with one side always facing the Sun and the opposite

side always facing deep space; this should simplify the thermal control system analysis and design task, helping to keep engineering costs to a minimum.

Baseline Launch Opportunity

The baseline orbit was not chosen casually. One of the greatest challenges faced by the developers of any secondary payload is the sourcing of a suitable launch opportunity. These are rarely known further than two years in advance of launch, and a primary payload with an orbit compatible with that needed by the secondary can be hard to find. MOST has the advantage that Canada's new Radarsat II satellite is being planned for launch into the same orbit as Radarsat I, an orbit which is ideal for MOST.

Radarsat II is currently planned for launch in November 2001 on a Boeing Delta II launcher, which has a well-established secondary payload capability. Discussions are proceeding with the Radarsat II Program at CSA, regarding the potential to fly MOST with Radarsat II. (Other launch possibilities are also being investigated by the CSA for MOST, in case the Radarsat II launch opportunity fails to become available.)

Operations Scenario

MOST mission operations are phased as follows:

- Following launch, the launch vehicle maneuvers to the desired orbit for MOST, and releases the satellite.
- The satellite then is detumbled, conceptually using the Earth's magnetic field and the Sun as attitude references, ending in a Sun-pointing attitude.
- The telescope's boresight is slewed towards the first selected target star.
- The attitude control system then operates to keep the telescope pointed towards the target star, with sufficient accuracy to allow the required science photometric precision to be achieved.
- The first target star will be tracked for a commanded duration, up to the time when it has drifted to near the boundary of the CVZ (up to 7 weeks). At the end of this period, the telescope's boresight will be slewed to the next target star.

The mission does not rely on continuous radio contact with the ground. Intermittent contact is planned for, with a pair of ground stations to be located in Toronto and Vancouver.

To achieve a reasonable level of robustness against unexpected anomalies, the mission requires that a "safe/hold" attitude control mode be developed to ensure continuity of power collection, along with a definition for

the conditions under which the satellite would autonomously enter this mode, and the operations required to regain normal operations from this mode.

Mission Duration

It is anticipated that these operations will involve up to 7 weeks of observation of each target star in turn, for the duration of the useful life of the satellite. A useful lifetime of 5 years or more can be expected before the satellite's orbit drifts significantly away from the dawn/dusk condition due to atmospheric drag, Lunar/Solar gravitational perturbations, etc. The satellite has no consumables, and items of equipment that will degrade over time (e.g., solar arrays, batteries, reaction wheel bearings, digital electronics subjected to radiation) are expected to last for a similar period. The science team estimates that the main science objectives can be met within the first year of operations, but there are more than enough bright target stars accessible to MOST to keep it busy well after that.

System Design Concept

System Architecture

The equipment that will be developed to support the MOST mission comprises two major elements, the MOST Satellite and the MOST Ground Segment. The satellite is divided into a Bus and a Payload, and the Ground Segment into Ground Control Stations and GSE, which in turn are made up of Subsystems as shown in Table 1.

The guiding philosophy for design of this system is to employ proven microsatellite designs as a starting point, making minimal adaptations to these in order to enable the core science objectives of the mission to be met. The resulting system design allows the mission to be achieved while re-using structural, power, on-board computing, telemetry & telecommand and ground station subsystem design envelopes from previous successful microsatellite missions. A new instrument design was needed, and some new attitude control capabilities had to be developed to augment ACS designs used in past satellites.

Most of the inter-relations between subsystems are fairly standard, as illustrated in Figure 5. One somewhat unusual interface has been specified, between the science instrument and the attitude control subsystem. In addition to collecting science data, the

Table 1: System Architecture

Primary Element	Secondary Element	Subsystem
<i>Satellite</i>	<i>Bus</i>	Structure
		Thermal Control
		Power
		Attitude Control
		Telemetry & Telecommand
	On-Board Computers	
<i>Payload</i>	Instrument	
	Payload Data Processors	
<i>Ground Segment</i>	<i>Ground Control Stations</i>	Toronto GCS
		Vancouver GCS
	<i>Ground Support Equipment</i>	Development GSE
		Launch Support GSE

instrument will be used to collect data measuring the pointing error between the instrument's boresight direction and the target star's direction. These data will be provided to the ACS, which will use them to control this pointing error towards zero.

Attitude Control Accuracy Trade-Off

With this system architecture, attitude control accuracy becomes a driving system parameter:

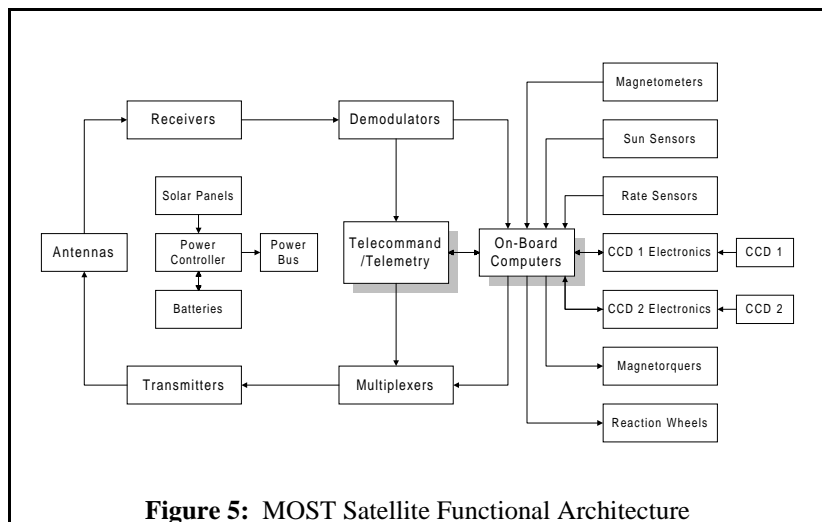

Figure 5: MOST Satellite Functional Architecture

- An upper limit on acceptable pointing error can be determined by evaluating the effects of pointing error on instrument photometric precision. A narrow field of view is necessary to eliminate signals from background stars in the vicinity of the target star. Wandering of the target star's image within the instrument's field of view can also degrade photometric precision, depending on the level of calibration across the image plane that can be achieved.
- Achieving high-accuracy attitude control depends on achieving even higher-accuracy pointing error measurements from the instrument, at a sufficiently high measurement rate to be consistent with the attitude control subsystem's controller bandwidth. Below some level of pointing-error accuracy, this effect can lead to instrument requirements (e.g., in terms of resolution, and sample rate) that are more stringent than and incompatible with the science-related instrument requirements. This would lead to a more expensive instrument design than otherwise.

The attitude accuracy parameter thus can be used to trade instrument cost against photometric precision. For the current baseline instrument and ACS designs, a maximum instrument boresight pointing error of 25 arc-seconds has been selected. For reference, note that the typical level of pointing accuracy achieved by previous microsattellites has been about 1 degree (3600 arc-seconds); while larger satellites routinely achieve < 25 arc-sec accuracies,

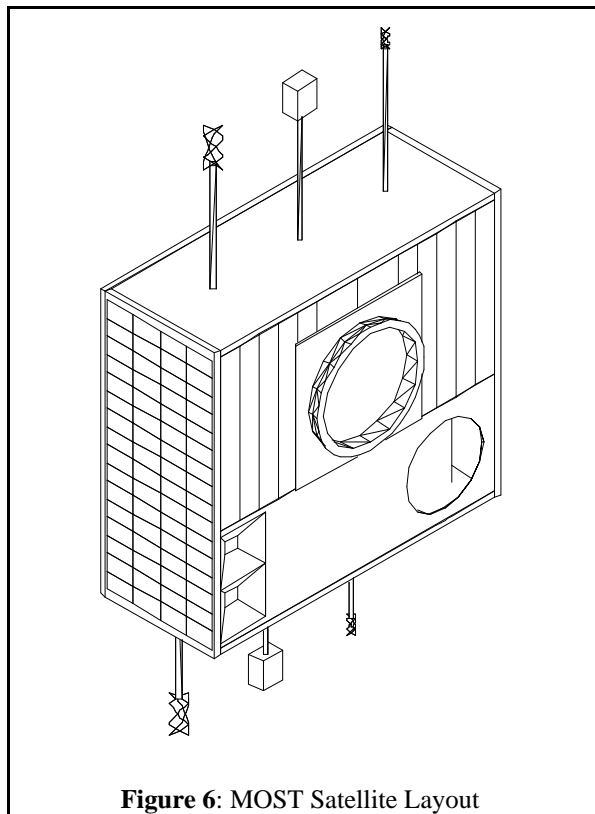

Figure 6: MOST Satellite Layout

MOST demands an improvement in the microsattellite ACS state of the art.

Satellite Overview

Satellite Layout

The satellite's general layout is shown in Figure 6. It is driven by the secondary payload volume envelope provided by the Delta II launch vehicle. It incorporates a stacked set of Bus functional modules, with an adjacent Payload bay defined by a set of panels (including the solar array panels. The overall dimensions (including an allowance for the launch vehicle interface hardware, but excluding appendages for antennas and magnetometers) are 63 by 58 by 25 cm.

Bus Overview

The main features of the MOST Bus design are:

- It is based on the stacked-tray modular concept that has been used successfully in the AMSAT Microsat series of satellites, as well as in the University of Surrey/SSTL UoSATS. The main functional elements of each subsystem (electronics boards, reaction wheels, batteries) will be housed within a set of trays of identical cross-section, which will be bolted together to form a "box-beam" structural back-bone for the satellite.
- On 5 sides, the stack of trays will be covered by a set of structural panels, on which will be mounted photovoltaic cells, and booms for antennas and magnetometers.
- On the remaining side of the tray stack will be mounted a standard Delta-II Payload Adapter Assembly (PAA): one-half of a Marmon-clamp ring plus supporting structure.
- The Power, Telemetry & Telecommand, and On-Board Computers subsystems are closely based on subsystem designs that have been flown on other microsattellites.
- The Attitude Control subsystem uses as its foundation a design that has been used successfully in other microsattellites: magnetometers and magnetorquers are used to provide a simple but low-accuracy basic attitude control capability, used for detumbling and safe/hold modes.
- To achieve the high-accuracy attitude control capability needed to achieve the science goals, a set of small reaction wheels will be used to provide 3-axis actuators. These will be actuated based on pointing error signals generated by the science instrument, when operating in fine-pointing mode.

Payload Overview

The MOST satellite’s payload comprises the science instrument, along with the electronics required to operate it and interface it with the on-board computers. The main requirements on the instrument are:

- To collect science photometry data from the selected target star. This is required to be photometrically very precise in order to maximize the signal to noise ratio, to be photometrically stable over sample runs of several weeks duration when subject to up to 25 arc-seconds of instrument boresight wander, and to have a wide dynamic range in order to maximize the number of useable target stars.
- To collect star-field image data with which the ACS will measure the instrument’s pointing error. The baseline requirement here is to produce star field image data once per second, using variable exposure times of as little as 1/10 of a second.

The main requirements on the payload data processing electronics are to operate the instrument’s camera, to process photometry measurements from the target star using variable exposure durations between 1 and 100 seconds, and to process the star-field image data at a 1 Hz rate with a maximum latency time of one second to produce boresight pointing error measurements with an accuracy of 1 arc-second.

The science instrument features a CCD-based visible-light camera, which receives light through the largest optical telescope that can fit within the available volume and mass allocations. The baseline design has a 15-cm aperture, and is about 55 cm long. The CCD will be passively cooled, and its temperature actively controlled to maximize photometric precision.

System Resource Budgets

The current allocations of mass, orbit-average power and volume (in the form of tray-stack height) to each of the satellite subsystems are summarized in Table 2. The allocated values are estimates of the amount of each resource needed by each subsystem, based on preliminary designs of each subsystem. The “Satellite Total” represents the total secondary payload mass that the Delta-II launcher can support, the worst-case orbit-average power available from the baseline power subsystem design, and the total tray-stack height available in the baseline layout. The amount of system margin that remains available is fairly comfortable, for this stage of the design process.

Ground Stations Overview

Table 2: Satellite System-Level Budgets

Subsystem	Mass (kg)	Power (W)	Tray Height (mm)
Structure	13.9	0	0
Thermal Control	0.6	0	0
Power	6.8	0	35
Attitude Control	7.8	12.6	146
Telemetry & Telecommand	2.3	5	122
On-Board Computers	1.3	5	45
Instrument	7.4	3.4	26
Payload Data Processors	1.2	2.5	32
System Margin	8.7	13.5	172
(%)	17%	32%	30%
Satellite Total	50	42	578

A large number of ground stations will be able to communicate with the MOST satellite. These can be grouped in two classes:

- A pair of ground control stations will be developed, that will be used to issue commands to operate the satellite’s payload, attitude control subsystem, and other housekeeping functions. These will be located at the University of Toronto and the University of British Columbia.
- Amateur communications ground stations operated by AMSAT members will also have access to the satellite, through a communications payload to be provided by AMSAT. Tentatively, these will be used to provide a digital store-and-forward packet communications service.

Both types of ground stations will use a similar design: commercial UHF/VHF transceivers with programmable Doppler correction, L- and S-band up- and down-converters, and AMSAT-developed satellite tracking and radio-operation software running on commercial PC-class computers. These are inexpensive to develop and reliable in operation, and have the data throughput capacity needed to downlink the data generated by the satellite’s payload.

Subsystem Summaries

Payload

The payload consists of a telescope which looks out the side of the bus via a “periscope” mirror and feeds a CCD camera (cooled by a passive thermal control system and radiators) whose electronics interface with the on-board computers. The current concept for this instrument is shown in Figure 7.

The instrument serves two roles:

1. An ultraprecise photometer for science measurements.
2. A star sensor providing data to the Attitude Control Subsystem (ACS).

The latter function requires a fairly large field, while the former requires a very clean “point spread function” (PSF) for star images and minimal scattered light. As a result, we have adopted a Maksutov optical design which provides an unvignetted field of about 2 x 2 degrees and has no support struts for the secondary mirror which would introduce diffraction spikes and additional scattering.

The size of the telescope is limited by the available volume in the bus. The 15-cm aperture is the smallest that still offers good photon-counting statistics for a reasonable selection of science targets.

To keep costs low and reliability high, the current design includes no moving parts. The truss-like mechanical structure is athermal, with components of various CTEs (Coefficients of Thermal Expansion) carefully chosen so the optics maintain the same focus across the full range of temperatures to be encountered by the payload (from the lab bench to orbit). There is only one broadband filter (since the primary science goals can be achieved without multicolour data) and hence, no motorised filter wheel.

The prime detector of the instrument is a large-format (~760 x 1152 pixel) CCD cooled to -50C and stable to 0.1C per hour to keep readout noise below the stringent photometric error budget. The device will be partitioned so that two regions can be read out independently at different clocking rates.

One portion of the CCD, with a field of about 0.5 x 0.75 degrees, will collect star-field image data (slightly defocused) with which the ACS will determine the instrument's pointing error. The baseline requirement here is to produce star-field images at least once per second, with exposure times as short as 0.1 sec. Signal-to-noise requirements are not stringent, and stars as faint as magnitude 10 - 11 will be suitable for guiding.

The other portion of the CCD will be dedicated to

science data. The instrument must be capable of photometric precision of a few ppm even when the star images wander by up to 25 arcsec (the nominal performance of the ACS) in exposures of 1 - 60 sec. In-focus imaging photometry would require us to characterise the pixel-to-pixel sensitivity variations (“flat-fielding”) of the detector on the ground and in orbit to precisions never before achieved. Instead, we direct the starlight onto a Fabry lens in the camera window, designed to produce an extended image (about 40 pixels in diameter) of the telescope pupil on the CCD which moves by less than 0.1 pixel even if the star beam wanders by as much as 25 arcsec. This makes the instrument very insensitive to detector sensitivity gradients.

(Note that while the instrument's requirements have not changed substantially from those presented at this conference last year, several important design changes have been made. In particular, the telescope optics have changed from Cassegrainian to Maksutov, the two CCD detectors for science and star-sensing data collection have been replaced with a single detector, and the beam-splitting mirrors have been deleted. These changes result in a large improvement in the instrument's photometric precision.)

Payload CCD thermal control involves two main components:

- A “cryocooler” module (developed by CRESTech under an earlier program) will be used to produce a low-temperature heat-sink, from which heat from the CCDs will flow. The cryocooler employs a set of second-surface mirrors and baffles to radiate heat from its mounting-point on the anti-Solar-CVZ-facing side of the satellite. It is sized to keep the CCDs at below -50 C.
- Heaters mounted by the CCDs will be actively controlled, based on measurements taken by temperature sensors, to maintain changes in the CCD

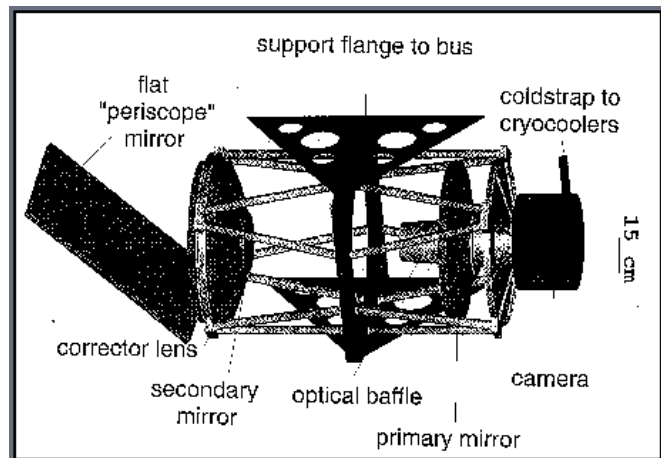

Figure 7: The MOST Instrument

temperatures to within 0.1 C per hour.

To minimize heat flow into the instrument from the satellite bus, insulating stand-offs and multi-layer insulation will be used to separate the two.

The payload data processing electronics must 1) operate the CCD, 2) convert the raw CCD data to a form suitable to be stored and downlinked, 3) flag any deviations from nominal photometric performance and alert the ground station on the next pass, and 4) process the star-field image data to produce boresight pointing error measurements with an accuracy of at least 1 arcsec. The design for these electronics has heritage from designs developed at UBC for CCD cameras for use in terrestrial astronomical observatories, taking into account processors that have flight heritage; the baseline design uses two digital signal processors (DSPs, baselined as TI TMS320C31): one to carry out star sensor software processing, and the other to carry out science data processing. Each DSP is allocated 1 MB of local RAM memory protected by hardware EDAC. The boot PROMs for the digital signal processors are built into the processor chips. They are to be programmed on the ground, so that if one of the DSPs is reset, it can recover back to an operational mode. Should one of the DSPs cease to function temporarily, a single DSP can satisfy basic data processing needs.

Structure

The MOST microsatellite is a rectangular box, 63× 58× 25 cm. The concept for the bus structure has three primary elements:

1. A set of stackable trays, into which electronics boards, batteries, reaction wheels, etc. can be mounted. The design details are driven by the volume and PAA location available in a Delta-II launcher for secondary payloads; unlike other satellites that have used the stacked-tray structure approach, for MOST the trays are oriented to “lie on their sides” during launch, with the PAA mounted to the side of the stack. To provide sufficient strength in this configuration, shear plates are inserted between each tray.
2. An instrument bay, which is an enclosure for the instrument, and also provides mounting points for solar panels. This is constructed from aluminum honeycomb panels.
3. A Payload Adapter Assembly (PAA), which bolts onto the side of the stack of trays, and is used to clamp the satellite to the launch vehicle (via a Marmon clamp arrangement). The NASA Delta II Secondary Payload Planner’s Guide specifies the design of the interface ring for this PAA.

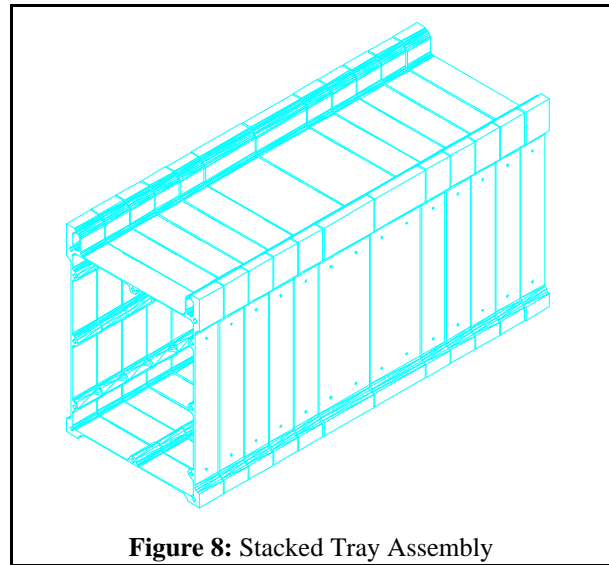

Figure 8: Stacked Tray Assembly

Reports from other developers indicate that the stacked-tray concept results in significant simplifications in the system development, integration and test process, which result in cost savings. The stacked tray assembly is held together by titanium tie rods.

The telescope “enclosure” consists of two honeycomb panels located at the bottom and bottom inboard sides of the satellite. Cutouts are provided for the telescope aperture and cryocoolers on the inboard panel (nominally facing away from the sun). Three solar arrays are to be fixed to the exterior of the bus structure via attachment bolts. Relative to the launch vehicle, they will be mounted on the outboard and side faces of the satellite. The solar panels complete the telescope enclosure. The payload adapter assembly is mounted against the electronics trays, on the inboard side.

The structure has been designed to accommodate conservative launch loads of 10G (specified by the Delta II launch vehicle guides) with an ultimate safety factor of two. Initial finite element analysis indicates that the structural design is more than adequate for the Delta II launch (the worst case loads occur during launch), with maximum deflections on the order of 0.1 mm.

The stacked tray assembly, as shown in Figure 8, consists of several electronics trays, the heights of which can be customized to the specific components that are housed. The two center trays behind the payload adapter assembly contain heavy components such as reaction wheels and batteries to place the satellite mass center as close to the launch vehicle attachment as possible. 2-mm-thick shear plates separate the electronics trays to strengthen the stack.

The electronics trays have nominal dimensions of 23× 31 cm and are made of 6061-T6 aluminum. A channel is provided for wiring harnesses at the top of each tray. The wiring channel is covered by a 1-cm thick aluminum

honeycomb panel, with cutouts for the antenna and magnetometer standoffs mounted on the top face of the satellite.

The payload adapter assembly (PAA) for MOST consists of a square plate with the adapter ring protruding. The PAA is machined out of a single piece of aluminum, with the adapter ring designed to mate with the Delta II launch vehicle secondary payload attach fitting. The payload adapter assembly plate is removable to allow for mating checks with the launch vehicle payload attach fitting, and is machined from high-strength aluminum alloy.

Thermal Control

The baseline approach to thermal control for the MOST bus is to employ entirely passive means. (Thermal control for the payload is semi-active, as discussed above.) While a variety of thermal control situations can arise over the course of the mission (e.g., during tumbling after release from the launch vehicle), one of the most challenging is the one in which the satellite will spend most of its time. During fine-pointing mode:

- The telescope aperture face of the satellite (one of the two “large” faces) will be aimed towards science targets in the anti-Solar CVZ. This face will see a combination of deep space and the Earth’s limb, the latter occupying at most ~40% of the face’s FOV, usually somewhat less. This face will tend towards a low temperature.
- The opposite “large” face will thus point within the Solar CVZ, and will always see the Sun (except during eclipses, which occur only during <3 months of the year), with solar aspect angles ranging from straight-on to 57 degrees off perpendicular. This face will be covered with photovoltaic cells, which are highly absorptive; it will tend towards a high temperature.
- From a bus-fixed reference frame, the Earth will appear to rotate once per orbit about the axis through these two faces; the other 4 smaller faces will each be exposed in turn to the Earth’s face and to deep space.
- As a result, a strong thermal gradient is prone to develop between the Sun-facing and anti-Solar faces.

Thermal control coatings will be applied to the 3 surfaces that aren’t covered by photovoltaic cells. The design objective is to keep temperatures for temperature-sensitive components (e.g., batteries) within acceptable ranges for the full range of operational orientations. Initial analysis indicates that application of white paint to the anti-Solar face can keep bus temperatures between 7 and 23 degrees C, if the solar arrays are thermally coupled to the bus structure.

Table 3: Fine-Pointing Mode ACS Requirements

Telescope-Frame Axis	Pointing [deg]	Stability [deg/sec]
Roll Angle (Boresight)	1.0	1.2
Pitch Angle	0.008	0.010
Yaw Angle	0.008	0.010

Power

The design concept for the power subsystem comprises the following components:

- ▶ A set of three solar arrays, mounted to the outboard and side faces of the MOST satellite, providing 14V.
- ▶ A rechargeable battery to provide power during eclipse, producing 12V during discharge. Analysis indicates that about 1 A-hr of energy is needed from the 12V battery.
- ▶ A battery charge controller circuit.
- ▶ Solar array peak-power tracking circuitry, for each solar array panel.
- ▶ A voltage regulator to provide some power at +/- 5V.
- ▶ A set of power-switching circuitry, to provide 12-14V and +/- 5V power through a number of computer-controlled switches, each equipped with a maximum-current shut-off capability. The switches are also commandable from the ground.

Based on preliminary power analysis, silicon solar cells covering the entire outboard and side faces of the MOST satellite will produce at least 48 W of power when in sunlight, more than enough power to support all functions and battery charging requirements. No solar panels are required on the top and bottom faces of the satellite where the antennas and magnetometers are mounted. These calculations assume that the main solar array does not deviate by more than 57° from the sun line (for a dawn-dusk sun-synchronous orbit). In addition, it is expected that the side panels never get closer to the sun line than 33°.

The secondary power system for the MOST satellite

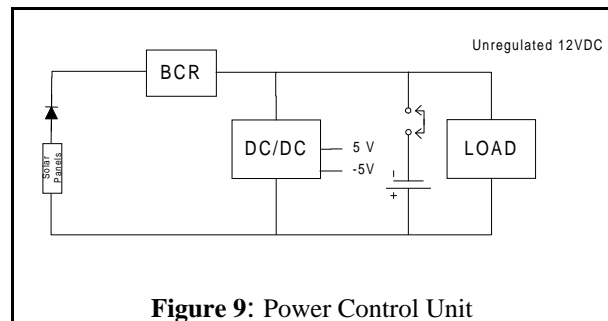

Figure 9: Power Control Unit

consists of NiCd batteries. Batteries are intended to be used during eclipses, which are relatively short-lived (17 minutes maximum) for dawn-dusk sun-synchronous orbits. The current battery design consists of 10 cells in order to achieve a nominal bus voltage of 12 V.

The design concept for the power control unit, illustrated in Figure 9), is based on designs with heritage from numerous AMSAT satellites. When the solar panels are illuminated by the sun, they set the bus voltage. Power is also supplied to the Ni-Cd batteries during this period in order to charge them through the Battery Charge Regulator (BCR). Peak power tracking is included in this scheme. A computer must operate in a loop with a DC to DC converter and controls the regulator in such a way as to manipulate the input voltage to the regulator.

Attitude Control

The requirements imposed by the mission on the MOST satellite's Attitude Control subsystem (ACS) are relatively demanding. While high-accuracy three-axis control is common among larger satellites, this type of design has almost never been used on microsatellites in the past (where "microsatellite" denotes a satellite of <100 kg, costing <\$10M). This has been due to lack of availability of small and inexpensive star sensors and reaction wheels, key components for an ACS that aims for accuracies in the arc-second range. To overcome this problem, MOST will employ a new design for a small reaction wheel that is being developed by Dynacon, and will use the science instrument as the satellite's star sensor.

During stellar observation, telescope pointing must be regulated to maintain the image of the target object within a certain area of the CCD detector array—the area of the CCD that is covered by one of the camera's Fabry lenslets. These lenslets each cover a circular area of the CCD, whose diameter is equivalent to about 25 arc-seconds of telescope FOV angular extent; the pointing accuracy requirement corresponds to keeping the target star's image within the bounds of the selected lenslet.

(Note that these pointing accuracy requirements are considerably more stringent than the ~1 arc-minute cited in this conference last year. This is due to the changes in the telescope design, particularly the adoption of Fabry lenslets, which no longer permit the target-star's image to wander around the CCD's surface.)

In addition to these pointing dispersion limits, the instrument's use as a star sensor poses an angular rate (stability) limit on the pointing, determined by the finite exposure time required to acquire an image, coupled with the need to avoid smearing of star images. The resulting telescope pointing regulation requirements are summarized Table 3.

In addition to telescope pointing regulation, the ACS is required to support the general operation of the satellite as described by the following general functions:

- *Attitude Acquisition and Stabilization.* There will be times during the mission (including the post launch and separation condition) when the satellite must recover from a state of unknown attitude motion (tumbling) and achieve a state of stable attitude.
- *Target Slew.* The satellite must be able to re-orient itself from one stabilized attitude to another, such as when repositioning the telescope to a new target star.
- *Momentum Management.* The ACS must manage the disposition of satellite angular momentum throughout the mission.
- *Safe/Hold Provision.* The ACS must provide for protection of the science instrument from damaging solar exposure, as well as ensure adequate solar array exposure for power generation throughout the mission.

The general architecture of the ACS is shown in Figure 10. It includes the following main components:

- Actuator Hardware:
Reaction Wheels (4, tetrahedral arrangement)
Magnetorquers (3 axes, 2 of each)
- Sensor Hardware:
Sun Sensors (2)
Magnetometers (2 × 3-axis)
Differential Star Sensor (1 × 3-axis)
Inertial Rate Sensors (4)
- Major Software/Functions
Orbit Model and Earth/Sun Ephemeris
Earth Magnetic Field Model
Inertial Attitude Estimator
Relative Motion Estimator
Coarse Detumbling B-Dot Law
Fine Detumbling Control Law
Fine Pointing Control Law
Wheel Speed Management Law
Safe/Hold Control Law

Magnetometers, magnetorquers and star sensors will be based on designs used on previous microsatellites developed by AMSAT and others. Detumbling and safe/hold ACS modes using this equipment will similarly be based on well-established microsatellite ACS design

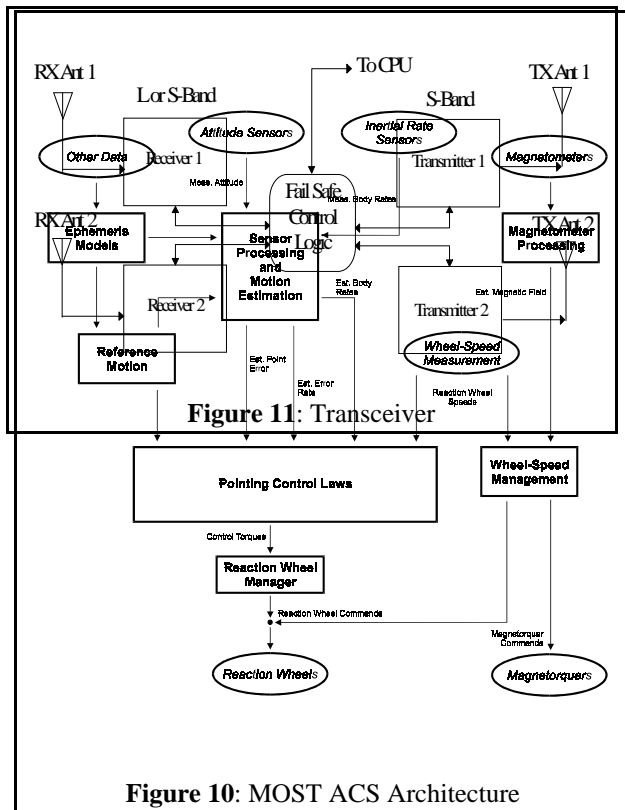

(High Performance Attitude Control)—this is an add-on to existing microsat-class attitude control systems that adds fine-pointing capability. The software component of HPAC, which includes all of the functions listed, has been developed in prototype form, and tested via simulation against the expected environmental disturbance environment for MOST. With a 1 arc-sec accuracy star sensor being sampled once per second, and with an ACS controller frame rate of 10 Hz, the simulation predicts an attitude estimation accuracy of about 2 arc-sec, and attitude regulation to <10 arc-sec >99% of the time (< 7 arc-sec >90% of the time). Validation of these simulation results is now underway at Dynacon, using a hardware emulation of the MOST ACS that is supported by an air-bearing platform.

Telemetry & Telecommand

The main requirement on the TT&C subsystem is to provide reliable uplink and downlink communications between ground control stations and the satellite. The satellite will generate at least 2 MB of data per day, all of which will have to be downlinked.

The baseline sun-synchronous orbits has a near-polar inclinations. Rather than attempting to achieve full-time communications with the satellite, the telemetry and telecommand concept chosen assumes intermittent contact. The concept involves using the same type of packet-communications approach that is used in controlling numerous AMSAT satellites.

Two ground stations are to be installed, the primary at the University of Toronto Institute for Aerospace Studies (UTIAS), and a secondary at the University of British Columbia (UBC). Whenever the satellite is over one of these ground stations, contact may be initiated. For the baseline orbit this happens between four and six times per day per ground station, with two groups of passes per day. Each group is centered 12 hours after the previous group, with two or three passes centered about 6 A.M. and two or three more centered about 6 P.M.

The cumulative pass duration per day for each ground station is about 60 minutes. The design uplink data rate of 9600 baud will support uplink of about 3.3 MB of data per day; at a design rate of 56.4 kbaud, downlinking of about 19 MB of data per day should be possible, through each ground station.

A common AMSAT approach to packet communications is employed throughout. In this way, the same communications software (and some hardware) can be used to support both science and engineering command and telemetry, and AMSAT store-and-forward communications.

The telemetry and telecommand subsystem includes

practices.

Dynacon will be providing a set of 4 of its commercial MRW (Mini-Reaction Wheel) modules for MOST. Each MRW incorporates a small (50 mN-m, 0.3 N-m-s) reaction wheel with a solid-state angular rate sensor, along with embedded sensor processing and local wheel speed control, into a single hardware module. With a mass of about 1 kg each, a size of 90×90×85 mm, and a power consumption of ~3.5 W, these MRW units are scaled to the very limited resources available within the MOST bus. The MRW design is at an advanced state of development; qualification-level testing on a flight-test unit is planned for late 1998.

Dynacon will also develop software algorithms (which will run on the Payload's DSP processors) to process star-field images to extract attitude information from them. These algorithms will carry out a *star-tracking* function, determining the satellite's yaw, pitch and roll angles with respect to an initial index image. (The *navigation* function, in which the index image is registered to absolute celestial coordinates, will be performed on the ground following downlinking of the index image.) Initial work on these algorithms suggests that attitude measurement accuracies of better than 1 arc-sec may be achievable.

The remainder of the ACS software, which will run on one of the OBC subsystem's two i386 computers, will be based on a Dynacon commercial product called HPAC

modems to support digital packet communications. Through this subsystem, it is possible to reset and manage the power for the main satellite elements during contingency situations, and provide a means of recovery if equipment like the on-board computer locks up.

The communications protocols and standards for the MOST mission closely follow those used in the amateur radio community, thereby drawing upon the experience available through AMSAT. The selected standards are as follows

- PACSAT File Protocol
- AX.25 Packet Data Protocol
- High-level Data Link Control (HDLC) Serial Communications Protocol
- Gaussian Minimum Shift Keying (GMSK) Modulation

The telemetry and telecommand subsystem includes two identical S-band transmitters and two identical L-band receivers for redundancy (Figure 11). Both receivers operate continuously, requiring about 2 W of power. Only one transmitter is on at any given time and draws about 3 W on average. The output power is selectable, should it need changing. Each transmitter and each receiver uses either an amateur-band radio frequency or a space science band frequency. Transmitters and receivers will be connected to the On-Board Computers via GMSK modems.

An important operational requirement of the MOST satellite is the capability of monitoring various parameters, such as temperatures and power levels while the satellite is in orbit. This will be done via a set of telemetry data collection boards, with one of each to be included in each tray where analog telemetry data must be collected. These boards will communicate their data to the On-Board Computers via the CAN data bus, reducing the amount of wiring needed between trays to just the CAN bus.

The antenna design for the MOST satellite consists of four quadrifilar helix antennas, two for reception and two for transmission. Circular polarization is used. Antennas are mounted on the top and bottom faces of the spacecraft (the long and narrow sides of the bus structure that do not have solar panels -- see Figure 12). On each side is mounted a receive/transmit antenna pair, spaced appropriately to avoid unwanted interference patterns between the antennas or between the antennas and the bus itself. The antenna patterns for the quadrifilar helices are hemispherical, providing excellent omni-directional characteristics.

Link budget calculations indicate that the parabolic dish antennas (L- or S-band) and loop yagis (L-band) selected for the ground stations (see below) can provide a 27.5 to

31.5 dB quotient of bit energy to noise power (uplink) despite losses in feed, propagation, and atmosphere, and polarization mismatch (linear polarization is used on the ground). These are excellent margins, considering that a 12 dB quotient corresponds to a 1×10^{-6} bit error rate. Larger quotients yield even lower bit error rates. For the downlink, the quotient is 24.5 dB.

On-Board Computers

The On-Board Computer subsystem receives commands from the ground stations, issues mode-change commands to the payload, processes and stores data collected by the payload, transmits that data to the ground when requested, and carries out computation and control functions relating to satellite bus functions (e.g., the Attitude Control subsystem).

The OBC subsystem design employs a pair of Intel 386-type processors, each with 2 MB of commercial-grade local memory protected by hardware error detection and correction (EDAC). One processor will carry out ACS functions while the other performs house-keeping, command and control functions. Two bootstrap PROMs are also included, one for each 386 processor. An Intel 387SX math coprocessor accompanies the 386 ACS processor, to increase the speed of attitude control computations.

The processors are cross connected to provide redundancy. In the event that one processor ceases to function properly, a single CPU would cover all basic satellite operations until the upset processor re-boots. (A permanent CPU latchup is considered unlikely in low-

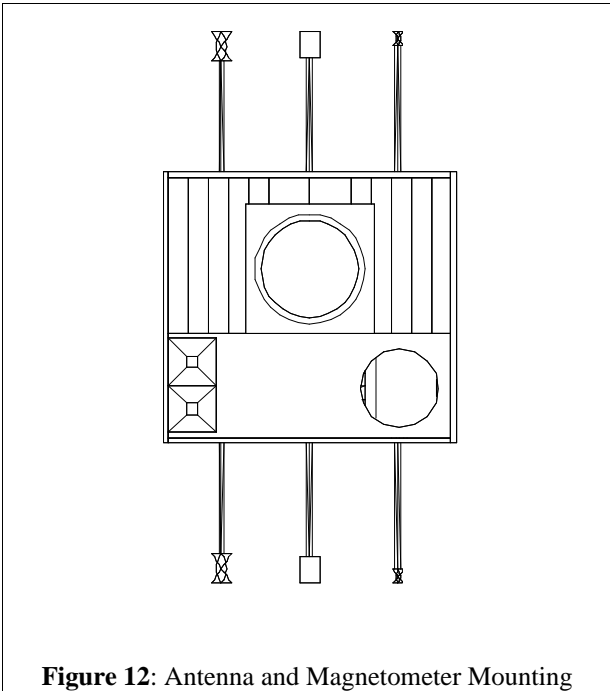

Figure 12: Antenna and Magnetometer Mounting

Earth orbit, as indicated by experience gained by AMSAT and others.)

In addition to the local memory provided to each CPU, 32 MB of static RAM is configured as a RAM disk for data storage. RAM devices are available that can provide a fast access, low power component that can operate effectively in extreme temperatures. Static RAM also has increased resistance to single event upsets over other types of RAM, and consume less power.

The RAM disk will be protected by EDAC software running on the main (housekeeping) 386. MOST is expected to collect approximately 2 MB of data per day. Assuming that in the worst case a maximum of seven days of storage without downloading data to the ground, 14 MB of memory is required for the mission. The software EDAC increases RAM requirements by 50%, adding an extra 7 MB. AMSAT is allocated an additional 11 MB to pursue their digital store-and-forward interests. Thus, in total 32 MB of RAM are required.

A Controller Area Network (CAN) bus connects all the processors, and the processors to most active elements in the satellite (e.g., the ACS components). The CAN bus has a 1 MB/s data capacity. Dual-redundant wiring is specified between CAN controller chips, to ensure that broken wires do not disable the bus. Separately from the CAN bus, command signal generator circuits will issue commands to open and close the power switches for all the on-board equipment.

The 386 processors have built-in watchdog timers. However, external watchdog timers are used to increase reliability in the case of single event upsets.

Software for the on-board computers include:

- ▶ The BekTek SpaceCraft Operating System (SCOS). This real-time, multi-tasking operating system has been used successfully on other microsats. It comes with PACSAT and AX.25 protocol software, and a package developed by Surrey Satellite Technology Limited that handles RAM-based file system management. BekTek SCOS also includes error detection and correction software to protect the main memory.
- ▶ Orbit propagator.
- ▶ Magnetic field model.
- ▶ Attitude estimation filter.
- ▶ Attitude feedback control calculations.
- ▶ Attitude control mode change decisions.
- ▶ Science instrument management software.
- ▶ Telemetry and telecommand subsystem management software.
- ▶ Watchdog software processes.
- ▶ Power control software.

The current concept is to include dedicated links between the 386 processors and the modems of the telemetry and telecommand subsystem, supplemented by a CAN-bus link. The approach to achieve reliability against computers entering an uncommandable state (from single event upsets, power transient effects or software errors) is for each of the 386s to keep watch on the other one, and to issue either a CPU reset signal or cycle the power if its partner fails to respond. In addition, the watchdog timer would reset both 386 computers if they both failed to respond after some longer period of time. As a final measure, computer reset commands can be uploaded directly via the telemetry and telecommand subsystem.

Ground Stations

The system concept includes two ground control stations, one located in Toronto at UTIAS, and the other in Vancouver at UBC. In addition, there are a large number of AMSAT stations that can access the digital store-and-forward function of the satellite, for amateur radio communications purposes. The two ground control stations are equipped to operate at both science-band and amateur-band frequencies -- the science frequencies are nominally used for all ground-control functions, and the AMSAT frequencies are used only for amateur operations.

The ground stations use equipment similar to that used by AMSAT members to contact other AMSAT satellites currently in operation. Both stations are identical. In addition, the Vancouver ground control station can be operated remotely from Toronto.

Ground station transmitters and receivers are responsible for Doppler correction (the satellite will not provide Doppler correction). High-gain tracking antennas are used for L-band uplink and S-band downlink, although loop yagis are an alternative for L-band operation. Linearly polarized ground station antennas communicate with the circularly polarized antennas on the satellite. This incurs a constant 3 dB signal strength loss due to polarization mis-match, but avoids deep nulls.

The ground control stations are equipped with computers to control the transmitters and receivers and antenna pointing gear, as well as send and receive communications packets, compensate for Doppler shift, form commands for the satellite, display and analyze engineering telemetry from the satellite, and perform some amount of limited display and checking of the science data downlinked from the satellite. The ground control stations are also equipped to archive engineering telemetry and science data, and to make the science data available to the missions scientists at remote sites (via the Internet).

A set of standard Pentium class computers will be used for the ground station control. A CD-ROM and tape backup drive serve as mass storage devices for archiving science data. With a download rate of 2 MB per day, a full year's operation requires only 730 MB of mass storage.

The ground station computer runs a program known as WiSP. WiSP is a fully-integrated program for operating digital satellites. It implements both the uplink and downlink protocols, manages all message files, updates the satellite schedule, and drives the antenna rotator hardware.

A commercially available piece of equipment known to AMSAT operators as a Kansas City Tracker (KCT) with Kansas City Tuner controls the pointing of the ground station antenna and the tuning of the transceiver. It is itself controlled by PC software which computes the orbital elements of the satellite. Based on these orbital elements, the KCT moves the antenna and sweeps the frequency of the tuner to account for doppler frequency shifts. The ground station antenna for each MOST ground station is a paraboloidal dish reflector (2 m diameter) for both L- and S-band communications; a two-axis gimbal will point the antenna with an accuracy of $\pm 1^\circ$.

The Terminal Node Controller (TNC), a device in the ground station which is a combination modem and packet radio controller, interfaces between the computer and the RF radios in the ground station. One possible commercially available TNC is a Paccomm Spirit II which supports the AX.25 protocol, GMSK modulation and the maximum downlink data rate of 64 kbps.

The transceiver operates in the VHF and UHF frequency bands and, on one side, interfaces with the modem in the Terminal Node Controller at baseband. On the other side, it interfaces at either UHF or VHF to an S-band converter.

Microsatellites for Space Science Missions

Many types of space science missions carry imaging payloads, which require a satellite bus that can reliably point the payload towards the desired targets, and maintain stable pointing for the duration of imaging operations. As far as we are aware, MOST will be the first microsatellite to operationally conduct imaging space science. The factors that allow MOST to do this can also be used to enable other, similar missions. MOST may be the harbinger of many future microsatellite-based space science missions.

In the past, imaging-class science missions have always been placed on platforms somewhat larger than the MOST bus, costing very much more than the MOST bus. This is partly because of the size and cost of the science instruments themselves. However, miniaturization of

detectors and electronics has enabled very powerful miniature instruments to be developed suitable for many useful space science applications. The impediment to placing these instruments on very small buses has its roots in the fact that achieving accurate attitude control requires a minimum complement of equipment on the satellite:

- Sensors capable of measuring attitude errors to an accuracy higher than the required pointing accuracy. For pointing accuracy requirements below 0.1 degree, the sensor of choice is a star sensor; Earth and Sun sensors cannot perform to accuracies significantly better than this, although they can serve useful auxiliary functions.
- Sensors capable rapidly sensing attitude motions, to enable implementation of high-bandwidth feedback control, which is needed to achieve high-accuracy pointing. The most common type of sensor used in this role is an absolute angular rate sensor, such as a rate gyro.
- Actuators capable of continuously generating torques about all three satellite axes. Reaction wheels, control moment gyros and thrusters all fall into this category, but magnetorquers do not; at any given time, one satellite axis is uncontrollable using these.
- Processing circuitry capable of implementing appropriate signal filtering and feedback command generation functions, in response to targeting commands. Often, this must also generate models of the satellite's orbit and target's relative location, as well as estimating external disturbances such as the Earth's magnetic field strength. In practice, this means a digital computer.

Equipment in each of these categories was, until recently, too large to fit on a microsatellite platform. However:

- Digital computers have miniaturized radically ever since the microprocessor was first developed, and this trend shows no sign of slowing down. While most high-budget missions have avoided using the latest in computing hardware (for reasons of engineering conservatism), some microsatellite-class missions have been willing to risk testing these in space, where they were found to perform quite well. MOST is employing flight-tested processors that are already becoming somewhat antiquated, but which nonetheless have the capacity to carry out the demanding functions needed by the ACS.
- Small star sensors have started to become available, at sizes and prices that are nearly within the budgets of microsatellites. MOST doesn't need a dedicated star sensor, because its science instrument is capable of producing exactly the type of data needed to fill that function. However, the technology will soon be available to enable other missions to achieve similar levels of attitude measurement accuracy.
- Old-style rate gyros were relatively large, heavy, complicated and expensive items of equipment,

consuming large amounts of power and with limited operating lifetimes. Laser- and fiber-optic-based solid state replacements for these have been developed to relieve some of these problems, albeit at a price that is still relatively high. Silicon-based rate sensors are now available that are very much smaller, lower in mass and power consumption, and very much less expensive (with somewhat less bias drift stability). MOST uses several of these to achieve high-bandwidth attitude estimation; these are similarly appropriate to any other fine-pointing space science mission.

- Most satellite reaction wheels are far too large for use on a microsatellite. However, in the past 2 years a couple of suitably small commercial reaction wheels have become available, and Dynacon is adding another with its MRW product.

With these components all becoming available, the technological stage is now set for more missions like MOST. However, this does not mean that *every* space science mission objective can necessarily be met by using a microsatellite platform; far from it! A propitious set of circumstances combined in the case of MOST to allow it to be carried out using a microsatellite platform:

- There is a good match between the basic science data-collecting objectives of this mission, and the capabilities of existing microsat bus designs to support payloads of the size, mass and power consumption required. The field of asteroseismology has been hampered by the obscuring effects of scintillation in the Earth's atmosphere, which has kept even the most basic objective (detection of Solar-like oscillations in other stars) from being met using Earth-bound instruments. At this young stage of this branch of astronomy, even a tiny telescope is capable of making ground-breaking observations, if located above the atmosphere. The MOST science team carefully resisted the temptation to set mission requirements above the point where a microsat-sized telescope would be sufficient.
- There is also a good match between the type of orbit that MOST needs in order to carry out the necessary long-duration stellar observations, and the likely availability of secondary payload launch opportunities to these orbits. The proposed dawn/dusk sun-synchronous orbit not only provides a very suitable CVZ size and scan rate, it also provides a stable thermal environment and relatively high (in microsat terms) power-generation potential, reducing the difficulty of the engineering requirements on all satellite subsystems.
- MOST requires a level of attitude control system performance that is considerably better than has been demonstrated on previous microsat missions. Fortunately, Dynacon has a strong expertise in the ACS area, and (with support from the CSA) has developed subsystem and component designs and

design tools that have allowed a High Performance Attitude Control system to be designed that meets the MOST requirements.

- The ACS performance goal is made easier to achieve because it is possible to make use of image data from the science telescope instrument, to provide attitude reference data whose quality is an ideal match to the attitude estimation process requirements for the mission.. (This is the ideal situation for a controls engineer: the quantity measured by the sensor corresponds directly to the quantity to be controlled.) Because the star sensor data is automatically registered to the science instrument's detector, this has the added benefit of virtually eliminating any sensitivity of star-tracking performance to instrument/bus alignment. Any misalignments that occur during launch (due to vibration loads) or on-orbit (say, due to thermal distortions of the bus), say between the telescope, the periscope mirror and the bus, will be automatically compensated for by the ACS's fine-pointing feedback controller. This greatly reduces design and testing costs associated with maintaining precise alignments.
- The University team members have expressed strong interest in the MOST mission, and their support brings access to the types of additional resources and areas of expertise that have characterized other successful, low-cost microsat missions in the past.

Designers of other space science missions who are contemplating the use of a microsatellite platform may want to compare the circumstances of their missions to these.

Acknowledgements

The MOST Phase A project was carried out under contract for the Canadian Space Agency's Space Science Branch, under the Small Payloads Program (SPP). The MOST team wishes to acknowledge the guidance and support provided by SPP Program Manager Glen Rumbold (who developed the Program Plan for the SPP, laying the groundwork for MOST and other future low-cost SPP microsatellite missions), as well as the CSA's Project Manager for MOST, Glen Campbell. Special thanks is also extended to the Ontario Research and Development Challenge Fund and the University of Toronto for supporting the Space Flight Laboratory. Dr. Peter C. Hughes continues to play a major role in securing funds for the MOST mission and in helping to organize the Space Flight Laboratory.

References

1. Carroll, K.A., McTavish, D.J., Matthews, J. and Rucinski, S., "MOST: A Space Astronomy Microsatellite Mission," presented in poster session at

the 11th AIAA/USU Small Satellites Conference, Logan, Utah, Sept.15-18, 1997.

2. Available on the World Wide Web at http://www.dan.sp-agency.ca/www/spp_ao/ao.html.

3. Available on the World Wide Web at <http://www.astro.ubc.ca/E-Cass/1998-ME/Matthews/index.html>

8-metre Telescope Project and the Lyman/FUSE (Far Ultraviolet Spectroscopic Explorer) satellite, as well as the Commission on Variable Stars for the International Astronomical Union and the Board of Directors of the Pacific Space Centre. However, he's not quite as boring as this makes him seem.

About The Authors

- ▶ Kieran A. Carroll graduated from the University of Toronto in 1982 with a B.A.Sc., in 1985 with a M.A.Sc. and in 1992 with a Ph.D., all in aerospace engineering, specializing in spacecraft dynamics and control. He co-founded, and served for 5 years as President of the Canadian Space Society, during which time he participated in the development of the Canadian Space Agency's long-term plans for technology development, microsattellites and planetary exploration. He has worked at Dynacon since 1986, and currently oversees all of Dynacon's space engineering activities.
- ▶ Robert E. Zee obtained his B.A.Sc. (1993) from the University of Waterloo Systems Design Engineering Department. As part of the cooperative education program there, Dr. Zee worked for IBM, Spar Aerospace Limited, and Allied Signal Aerospace. After being awarded the NSERC 1967 Science and Engineering Scholarship, he then obtained his M.A.Sc. (1994) and Ph.D. (1997) from the University of Toronto Institute for Aerospace Studies (UTIAS). Dr. Zee has been the UTIAS technical manager for DICE, a Space Shuttle Middeck experiment. He is currently leading microsatellite development efforts at UTIAS and is manager of the Space Flight Laboratory.
- ▶ Jaymie M. Matthews graduated from the University of Toronto in 1979 with a B.Sc., and from the University of Western Ontario with an M.Sc. (1982) and Ph.D. (1987), all in astronomy/astrophysics. He has been an Assistant Professor at UBC since 1992. Dr. Matthews' research centres on stellar pulsation and asteroseismology, performing rapid high-resolution spectroscopy and photometry with some of the largest telescopes in the world. He made the first detection of rapid surface motions in an oscillating magnetic star (confirming that this new class of variables was indeed pulsating) and pioneered a new technique to probe the atmospheric structure of stars via their pulsations at different wavelengths. He sits on the Canadian steering committees for the Gemini International Twin